

OWNER'S MANUAL

TX200 COMMERCIAL TREADMILL

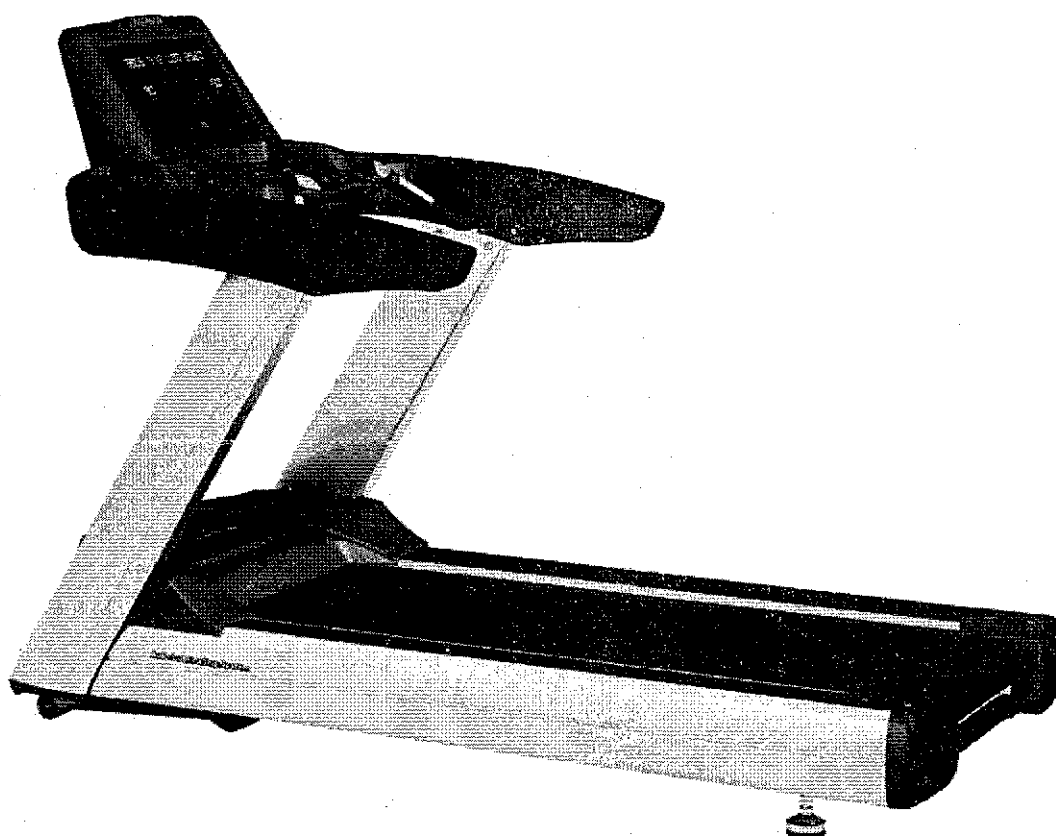

■ Please read all instructions in this manual before use the equipment and keep the manual well.

TABLE OF CONTENTS

IMPORTANT SAFETY INFORMATION	2
TECHNOLOGY PARAMETER	3
PACKING LIST	3
PARTS DIAGRAM	4
CONSOLE DISPLAY AND KEY FUNCTION	5
ASSEMBLY	6
OPERATING INSTRUCTIONS	8
MODE OF PROGRAM	9
DAILY MAINTNERANCE	12
DEBUGGING	13
EXPLODED DRAWING	14
PART LIST	15

IMPORTANT SAFETY INFORMATION



WARNING: To reduce the risk of burns, fire, electric shock, or injury to persons, read the following important precautions and information before operating the treadmill.

1. The treadmill has a user maximum capacity of 182kg for one person at a time.
2. For indoor only.
3. Do not put any objects around the treadmill to avoid any possible of injuries.
4. Keep the treadmill stably and carefully while changing position or moving.
5. Keep treadmill away from water, humid, heated and fire.
6. Never insert any object of body parts into any opening for picking. Switch off firstly.
7. Do not use accessory attachments that are not recommended to avoid any injuries and damage to treadmill.
8. The treadmill should be properly grounded and make sure that the outlet can supply enough electricity to the treadmill.
9. Wear training clothes and shoes which are suitable for running on the treadmill. Don't use the treadmill in bare feet.
10. To avoid injury, stand on the side rails before starting the treadmill.
11. The display of the heart rate is for reference only; it is not medical device and may be affected by many unknowable factors.
12. The user who has problems with his heart should use the treadmill under the doctor's directions.
13. Please select the right running speed according to your own physical condition.
14. Never leave the treadmill unattended while it is running. Unplug the treadmill after switching off.
15. Keep children under the age of 12 and pets away from the treadmill at all time.
16. To avoid electric shock, do not use this unit during a lightning storm.
17. Don't keep the treadmill running overloaded for a long time; the overload may damage the motor and the controller and also it reduce the service lifetime of bearing, belt and deck.
18. Don't touch any moving parts .
19. Stop using the treadmill in case of discomfort or when there is something wrong with the treadmill.
20. Long-haired user should pay more attention to your hair while using the treadmill.
21. Do not operate the treadmill with a damaged or frayed power cord. If the supply cord is damaged, it must be replaced by the manufacturer or its service agent or a similarly qualified person in order to avoid a hazard.
22. This appliance is not intended for use by persons (including children) with reduced physical, sensory mental capabilities, or lack of experience and knowledge, unless they have been given supervision or instruction concerning use of the appliance by a person responsible for their safety.
23. Children should be supervised to ensure that they do not play with the appliance.

Correct Disposal of this product:

This product should not be disposed with other household wastes throughout the EU. To prevent possible harm to the environment or human health from uncontrolled waste disposal, recycle it responsibly to promote the sustainable reuse of material resources. To return your used device, please use the return and collection systems or contact the retailer where the product was purchased. They can take this product for environmental safe recycling.



CAUTION: Before beginning this or any exercise program, consult your physician. This is especially important for persons over the age of 35 or persons with pre-existing health problems. Read all instructions before using.

TECHNOLOGY PARAMETER

Speed Scope	1—25Km/h
Incline Scope	-1--18%
Motor Power	5.3Hp
Input Voltage	220V±15% (50Hz or 60Hz)
Running Area	1620 x 580mm
Product Dimensions	2200 x 1000 x 1560mm
Surrounding Temperature	0-40 °C
Training Programs	23

PACKING LIST

No.	Description	QTY.
1	Main body	1
2	Monitor	1
3	Monitor tray	1
4	Vertical Frame	2
5	Tooling	1
6	Safety key	1
7	User' s manual	1

We have the rights to change the pictures and parameters, but are not responsible to notify the consumer.

PARTS DIAGRAM

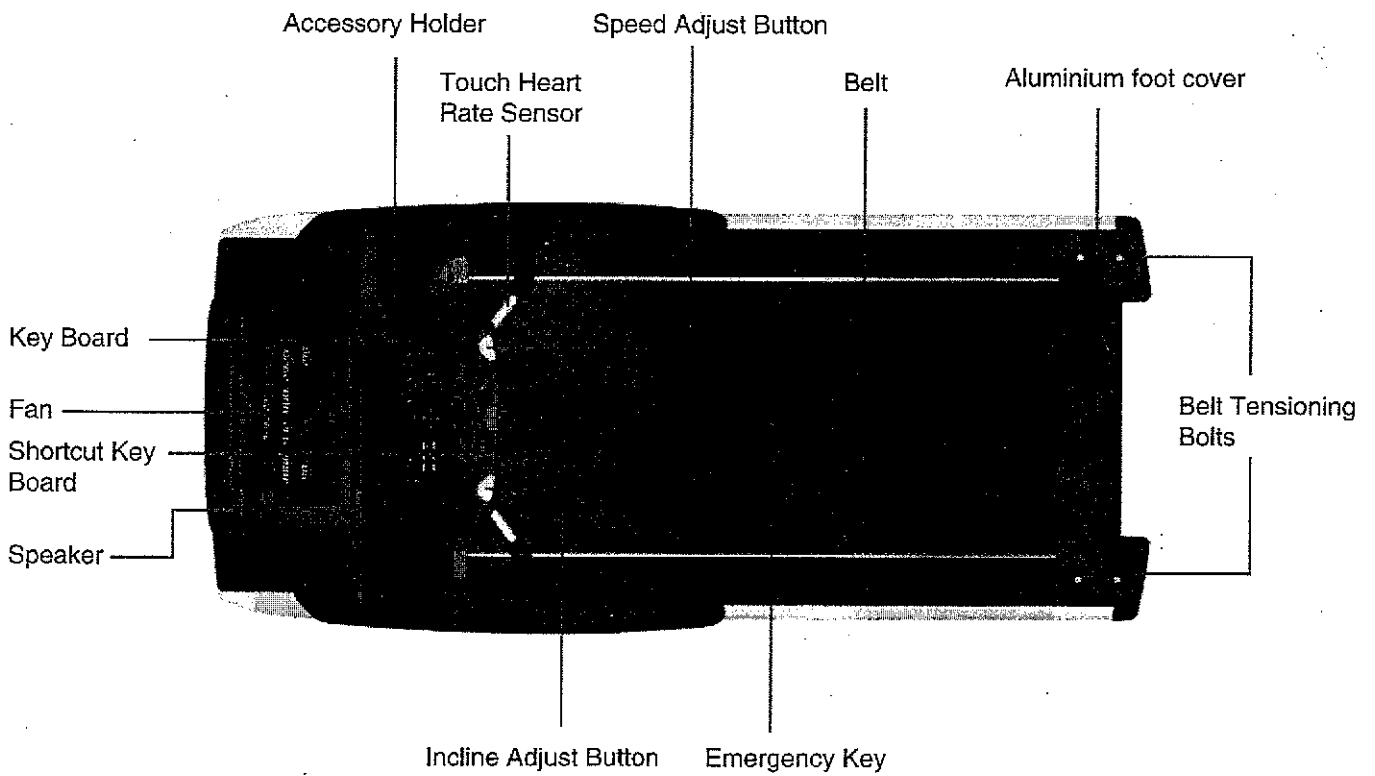
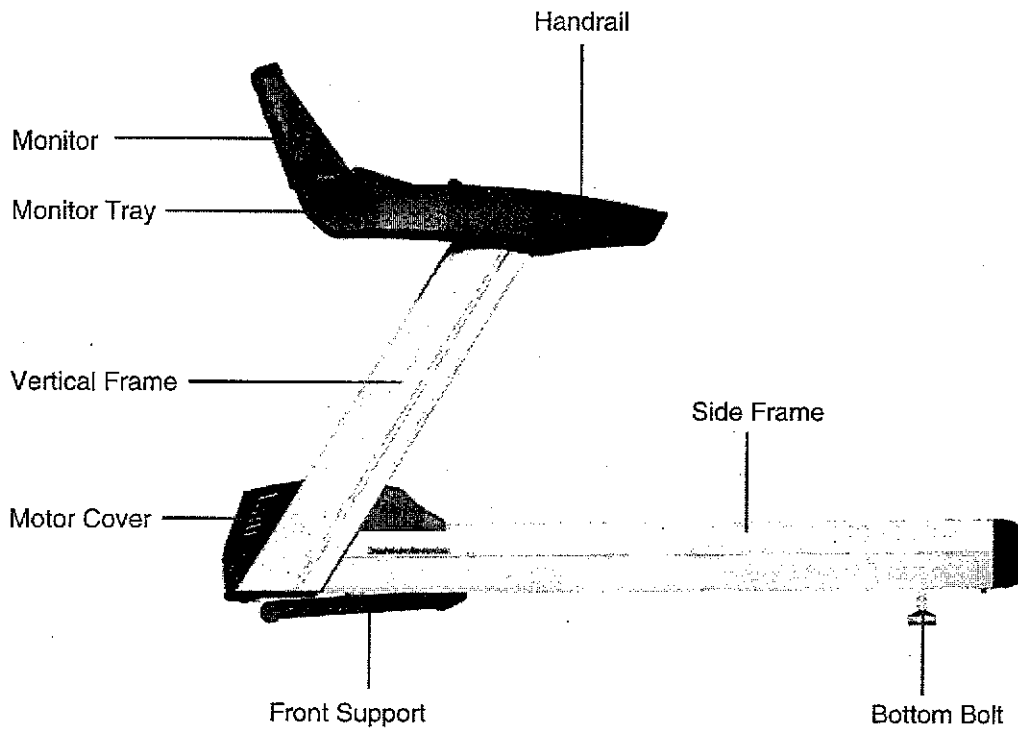

CONSOLE DISPLAY AND KEY FUNCTION

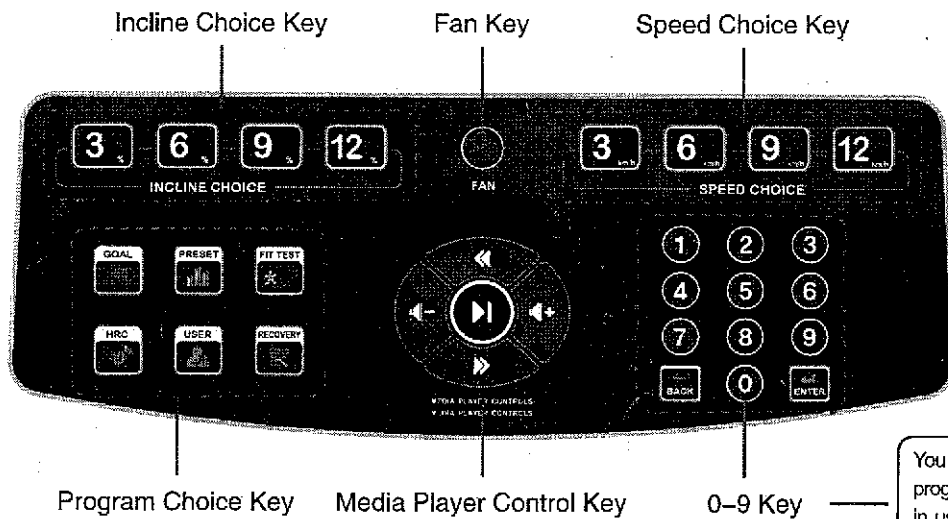
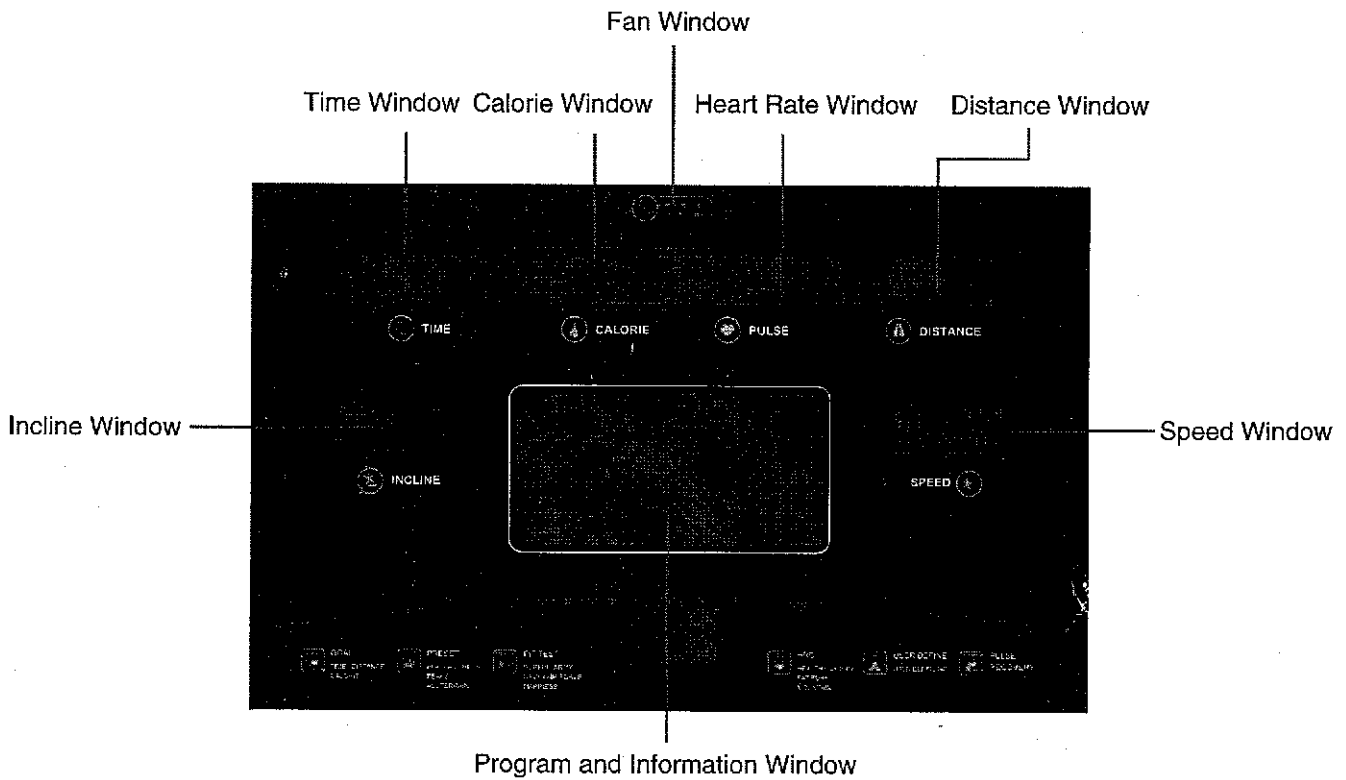

You can choose the number for program applying, change the speed in use through this key board. If you want to set the speed to 12.2Kmh, input '122', the heart rate window will display the number, press 'ENTER', the speed change finished.

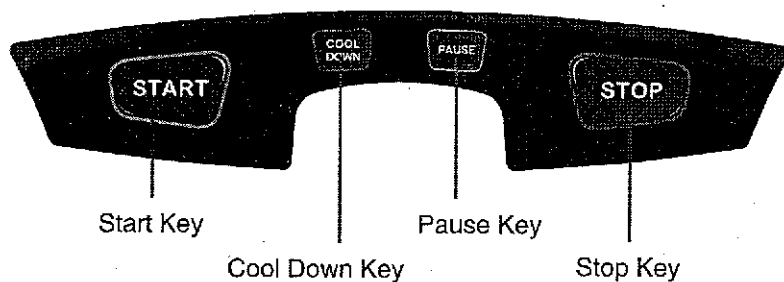

ASSEMBLY

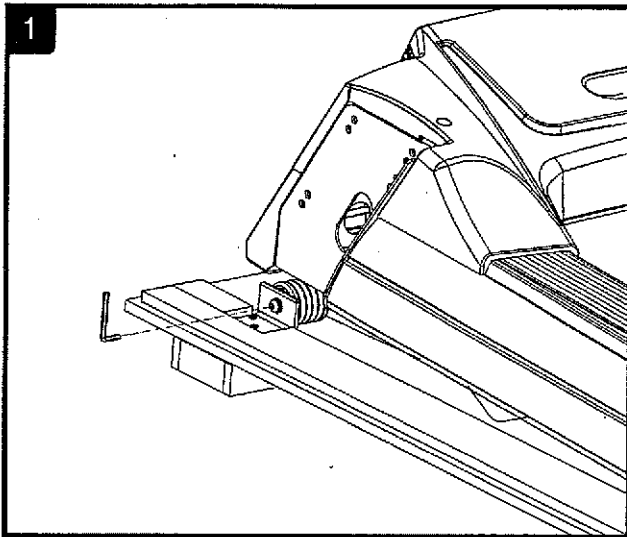

1
Open the package and unload the body machine with the 6MM wrench. (Attention to keep the bolts and the washer for next step.)

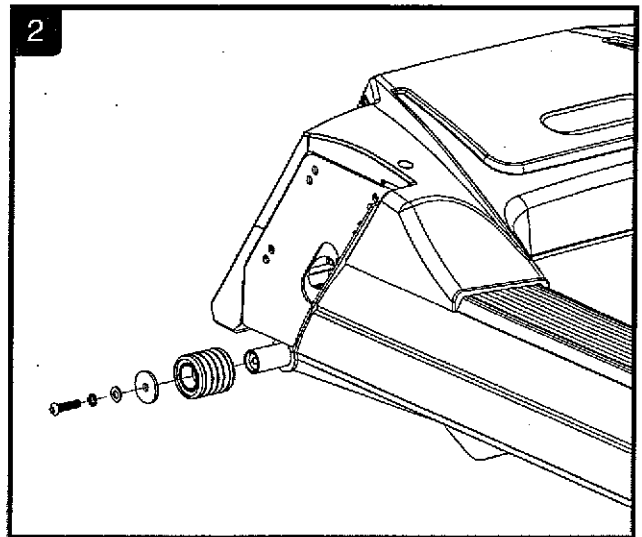

2
Move the equipment from the wood pallet, fix up the bolts to the machine with the 6MM wrench. (Pay attention to the procedure according the picture instruction.)

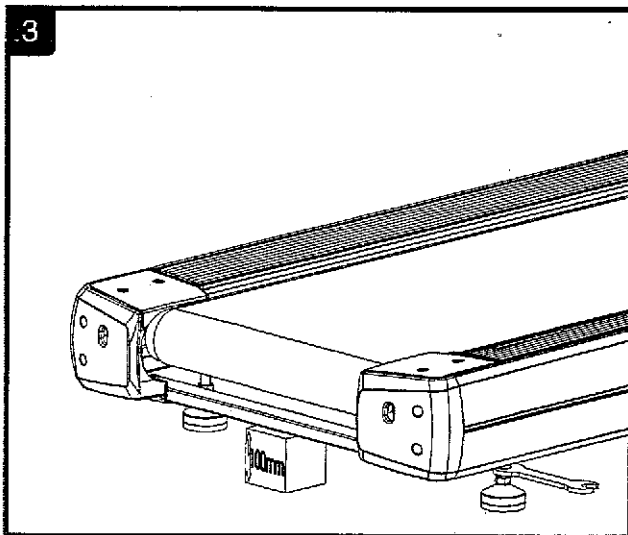

3
Use the wood brick (100x100x100mm) in the spare parts carton to underlay the equipment. Adjust the flat bottom by open spanner to touch the ground directly.

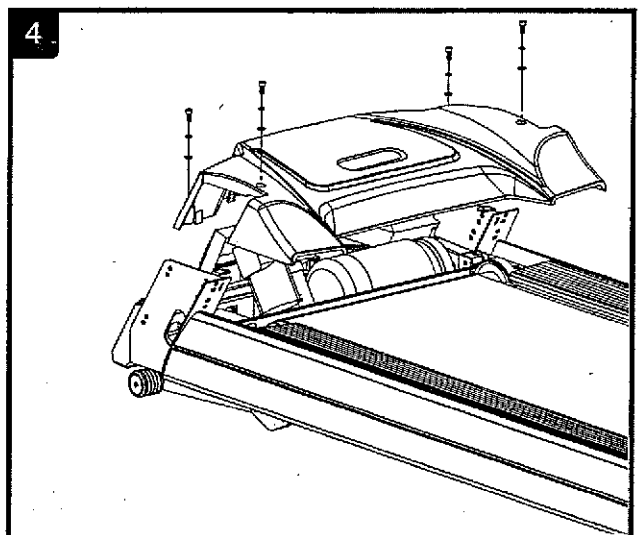

4
Unload the bolt with the screwdriver to open the motor cover. (Keep the cover and bolts for Step 9.)

ASSEMBLY

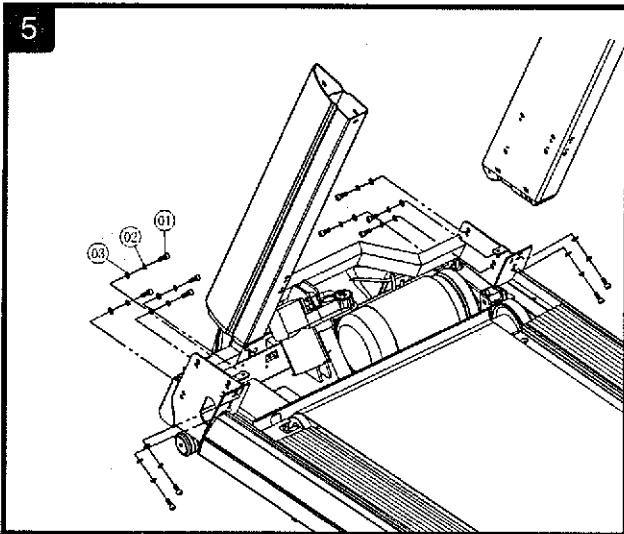

Install the vertical frame to the main body by using the hexagonal wrench. Please don't lock the bolt at once.
(Standard components packing No.:01)

01. Column Bolt	M8X20	12pcs
02. Spring Washer	M8	12pcs
03. Flat Washer	Φ16XΦ8.4X1.6	12pcs

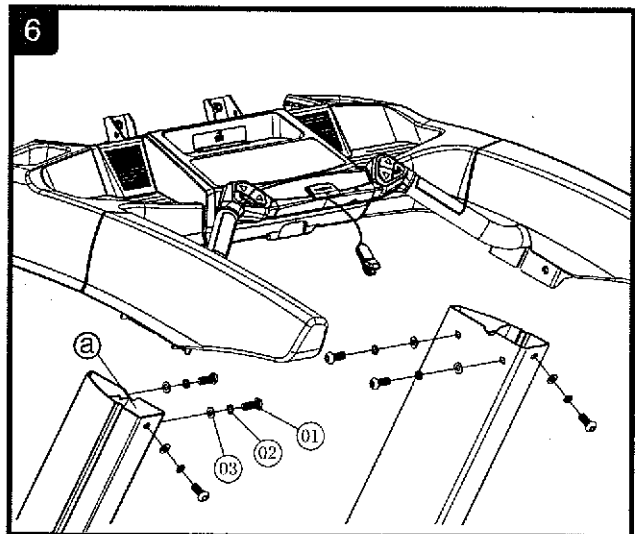

Pass the control line of the console tray through "a" position, pull out the line from the cable entry of the main body. Fix up the console to the vertical frame. Lock the bolt of step 5.

(Standard components packing No.:02)

01. Allen Bolt	M10x25	6pcs
02. Spring Washer	M10	6pcs
03. Flat Washer	Φ20xΦ10.5x2	6pcs

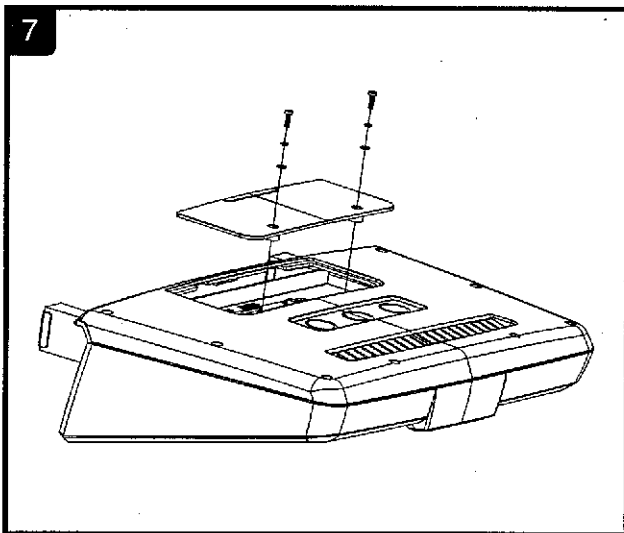

Set down the rear cover of the console. (Keep the bolts and the washer for step 10.)

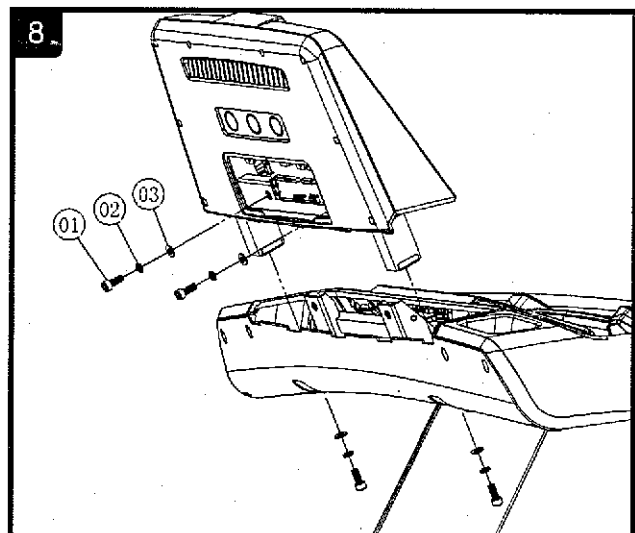

Connect the line of the console and the console tray. Fix up the console to the console tray.

(Standard components packing No.:03)

01. Column Bolt	M10x25	4pcs
02. Spring Washer	M10	4pcs
03. Flat Washer	Φ20xΦ10.5x2	4pcs

ASSEMBLY

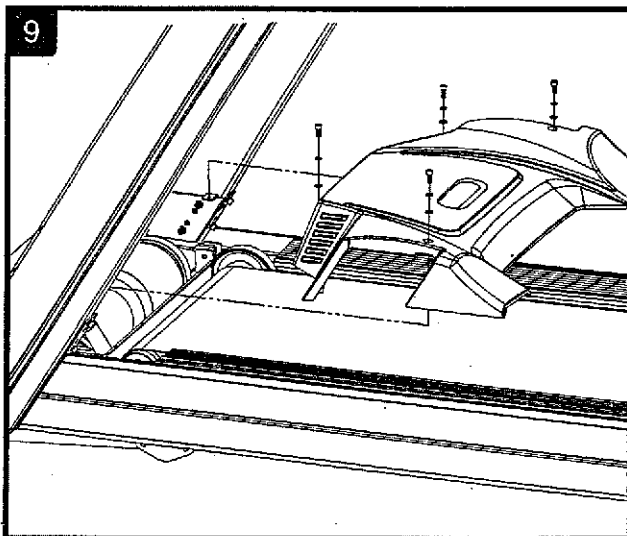

Use the bolt in step 4 to fix up the cover.

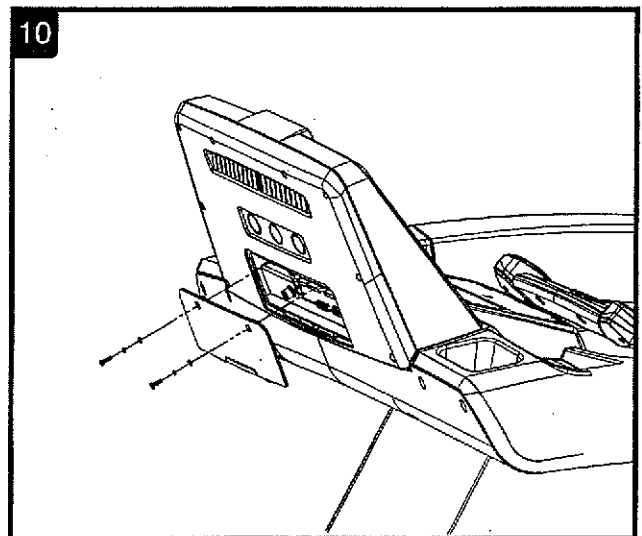

Use the bolt in step 7 to fix up the rear cover, adjust the main body to level at the same time.

OPERATING INSTRUCTIONS

Switch on the power, there is singing from the monitor. Lattice Window shows green colors in 2 seconds and then shows red colors in 2seconds. The nixie tube and lattice LED will show all in the 4 seconds. Meanwhile the incline motor decreased lowest point and return to the level. The speed window flashes and shows 'SI' . The time window indicates the total running time and distance window indicates the total distance. After 2 seconds the time window indicates '0:00' , the incline window indicates '0' , pulse window indicates 'Hr' , distance window indicates '0.00' ,calorie window indicates '0.00' ,speed window indicates '1.0' , Lattice window rolls and shows green articles first, then rolls and shows red articles. At this time you can control the console.

3 seconds after the start key is pressed, the running belt begins to move at 1 mph. During running customer can adjust the speed and incline value as desired. Press set key to select program mode

Press the stop key, 3 singing from the monitor and treadmill soft stop .The treadmill back to the ready time.

USB Player:

Connect the USB with the socket in the console, press start/stop to play the music, adjust the volume you need. The voice should not be too loud in the first in order to avoid the damage of the speaker. Please don't pull out the USB during the playing.

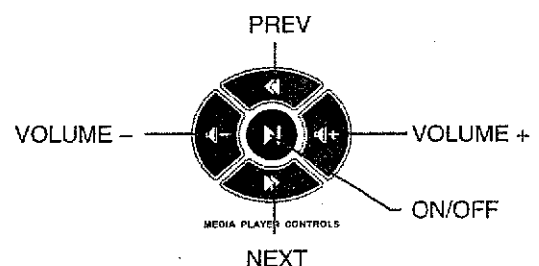

OPERATING INSTRUCTIONS

HEART RATE TEST:

When your hand on the pulse sensor, the window will flash and show "Hr" , the heart rate light on. The heartbeat value comes out 5 seconds later.

Testing before the exercise, stand on the two sideboards and hold the pulse sensor, after 20 seconds it will show your pulse value.

Testing after the exercise, stand on the two sideboards and hold the pulse sensor, after 20 seconds it will show your pulse value.

(Note: You'd better not test while exercising in order to get more exact value. The display of the heart rate is for reference only; it is not medical equipment and may be affected by many unknowable factors.)

MODE OF PROGRAM

● GOAL PROGRAM

1.Choose program:

Press program key "GOAL" continually to select "TIME COUNT DOWN PROGRAM" , "DISTANCE COUNT DOWN PROGRAM" , "CALORIE COUNT DOWN PROGRAM" .

The lattice window will show the current program during this period.

2.Parameter Input:

Press ENTER to prepare for the parameter setting. Press the speed +/- key or 0-9 keys to set the time, distance, calorie, weight, etc. Press ENTER to confirm the parameter, then you can set the next parameter. The lattice window will roll and show the current program during this period.

3.Start/Back

Press "START" after the parameter inputted to operate the program. Press "BACK" to make the treadmill to the ready time on the program setting condition.

● PRESET PROGRAM

1.Choose program:

Press program key "PRESET" continually to select "PLATEAU" , "HILL PEAKS" , "ALL TERRAIN" . The lattice window will show the current program during this period.

2.Parameter Input:

Press ENTER to prepare for the parameter setting. Press the speed +/- key or 0-9 keys to set the training time, weight, etc. Press ENTER to confirm the parameter, then you can set the next parameter. The lattice window will roll and show the current program during this

MODE OF PROGRAM

period.

3.Start/Back

Press "START" after the parameter inputted to operate the program. Press "BACK" to make the treadmill to the ready time on the program setting condition.

● FIT TEST PROGRAM

1.Choose program:

Press program key "FIT TEST" continually to select "GERKIN" , "ARMY NAVY" , "AIR FORCE MARINESS" . The lattice window will show the current program during this period.

2.Parameter Input:

Press ENTER to prepare for the parameter setting. Press the speed +/- key or 0-9 keys to set the weight, age, etc. Press ENTER to confirm the parameter, then you can set the next parameter. The lattice window will roll and show the current program during this period.

3.Start/Back

Press "START" after the parameter inputted to operate the program. Press "BACK" to make the treadmill to the ready time on the program setting condition.

Please wear the chest strap during the program running, the treadmill will mark based on your performance. The score will reflect the condition of your body.

● HEART RATE PROGRAM

1.Choose program:

Press program key "HRC" continually to select "HEALTH" , "CARDIO" , "FAT BURN" , "MOUNTAIN" . The lattice window will show the current program during this period.

2.Parameter Input:

Press ENTER to prepare for the parameter setting. Press the speed +/- key or 0-9 keys to set the heart rate goal, training time, weight, age, etc. Press ENTER to confirm the parameter, then you can set the next parameter. The lattice window will roll and show the current program during this period.

3.Start/Back

Press "START" after the parameter inputted to operate the program. Press "BACK" to make the treadmill to the ready time on the program setting condition.

Please wear chest strap during the program running, the treadmill will adjust the incline and speed according to the user' s heart rate.

● USER PROGRAM

1.Choose program:

MODE OF PROGRAM

Press program key "USER" continually to select "USER DEFINE 1-4". The lattice window will show the current program during this period.

2.Parameter Input:

Press ENTER to prepare for the parameter setting. Press the speed +/- key or 0-9 keys to set the training time, weight, incline and speed of every stage, etc. Press ENTER to confirm the parameter, then you can set the next parameter. The lattice window will roll and show the current program during this period.

3.Start/Back

Press "START" after the parameter inputted to operate the program. Press "BACK" to make the treadmill to the ready time on the program setting condition.

● HEART RATE RECOVERY PROGRAM

1.Choose Program

Press "RECOVERY" key to select heart rate recovery test.

2.Start/Back

Input the heart rate through chest strap or heart rate sensor before choose the heart rate recovery test. Press the "RECOVERY" key, the program begin to run after 60 seconds countdown of the lattice window. The test result shows on the distance window, reflect the body condition of the user.

Press "BACK" to make the treadmill to the ready time on the program setting condition.

TEST RESULT CHART:

F1.0-F2.0	F2	F3	F3	F4	F4	F5	F5	F6
Athlete	Regular exerciser		General		Less or irregular exerciser		No exercise or sickness	

● COOL DOWN PROGRAM

1.End up with 10Km/h

Use speed 5.5Km/h running 1 minute→Use speed 3.5Km/h running 1 minute→Use speed 2.7Km/h running 1 minute

2.End up with 3.54Km/h-9.9Km/h

Use speed 3.5Km/h running 1 minute→Use speed 2.7Km/h running 2 minutes

3.End up with <3.5Km/h

Use speed 2.7Km/h running 3 minutes. Running current speed if it is slower than 2.7 Km/h.

DAILY MAINTNERANCE

The running belt of the treadmill is imported which was made from special materials with lower coefficient of friction and higher of tensile strength; the running board is with double shock-absorb system and which surface is smooth and hard wearing.

● Lubricating

It can prolong the life of treadmill to keep it in clean situation, so it's necessary to clean usually the exposed running board and side foot-board, to wipe running belt by soft cloths with water, please pay attention to prevent the water from the underside of belt and over.

The friction of running belt will increase if it is unclean or lubricate less. It will damage the motor and monitor. Main feature of friction:

(1) Power off condition, it's too hard to move the running belt by feet.

(2) Treadmill running in middle speed, the running belt stop immediately once the safety switch turned off.

The treadmill uses the auto-lubricating system. When the console test the total distance reached the pre-set distance in the system, the lubricating motor begins to work. During using, user should check the auto-lubricating system timely. Add the oil quickly if find the oil bottle is empty. If the auto-lubricating system doesn't work well, please call the dealer immediately.

● Adjusting to loose or tight belt

The running belt was adjusted before it left the factory and after assembling, but after a period of usage, the belt will become loose, this circumstance is out of guarantee to be repaired. The user can adjust it by oneself. The loose belt will slip, but too tight belt may harm the motor, roller and itself. In general, there should be 5-6cm distance between the running belt and the running board. (Please turn off the power and pull the plug before move the running belt.)

The method judge the belt loose.

Change the speed to 1.5Km/h, grip the handrails both hands, try to block off the belt with feet. If the belt stop while the front roller still running, begin to run while move the feet, it means the belt too loose. The user may feel pause while running. Please adjust it asap to protect the life time.

Solution

Use special tool to adjust the left and right bolt clockwise. (1/4 circle a turn) Till the user feel no pause. (Picture A) Please adjust the both side the same time in order to avoid the belt off-center.

Attention: Not the tighter, the better. It will decrease the service life of the belt if fix too tight.

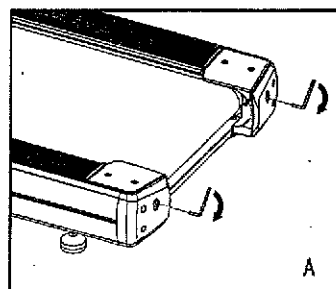

DAILY MAINTNERANCE

● Belt off-center adjustment

All the running belt were adjusted before the treadmill left the factory or after assembling, but after a period of usage, the belt may be off-centre, this circumstance is from the following causes:

- (1) The treadmill is not horizontal.
- (2) The feet of user do not stand on the center of belt.
- (3) The two feet of user are with different strengths.

Solution

Usually it can return after several minutes' moving, but if it can't, please adjust the bolt which is at the end of treadmill at unit of half-circle by a special tool together with the equipment. If the belt slants to left, please adjust the left bolt clock-wisely or adjust the right bolt counter clock-wisely (B). If the belt slant to right, it's adjusted oppositely(C). The excentric running belt is out of warranty .The user can adjust it by oneself.

Attention: Belt off-center will damage the belt badly, please adjust it once found.

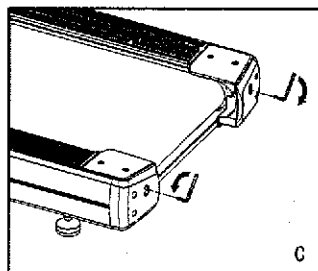
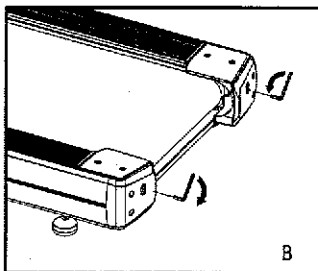

DEBUGGING

Time window will show the fault code when the treadmill break down.

Fault Code	Fault Reason	Solution
ER 1	Communication Fault	Please check the connection of communication line
ER 3	Over pressure protection	Please check the power and voltage
ER 4	Over current protection	Please check the motor and belt lubrication
ER 5	Over load protection	Please check the motor and belt lubrication
ER 7	Communication Fault	Please check the connection of communication line
ER 9	Inverter interior fault	Power off, reset 5 minutes later.
ER 10	Inverter interior fault	Power off, reset 5 minutes later.
ER 11	Inverter interior fault	Power off, reset 5 minutes later.
ER 12	Inverter interior fault	Power off, reset 5 minutes later.

EXPLODED DRAWING

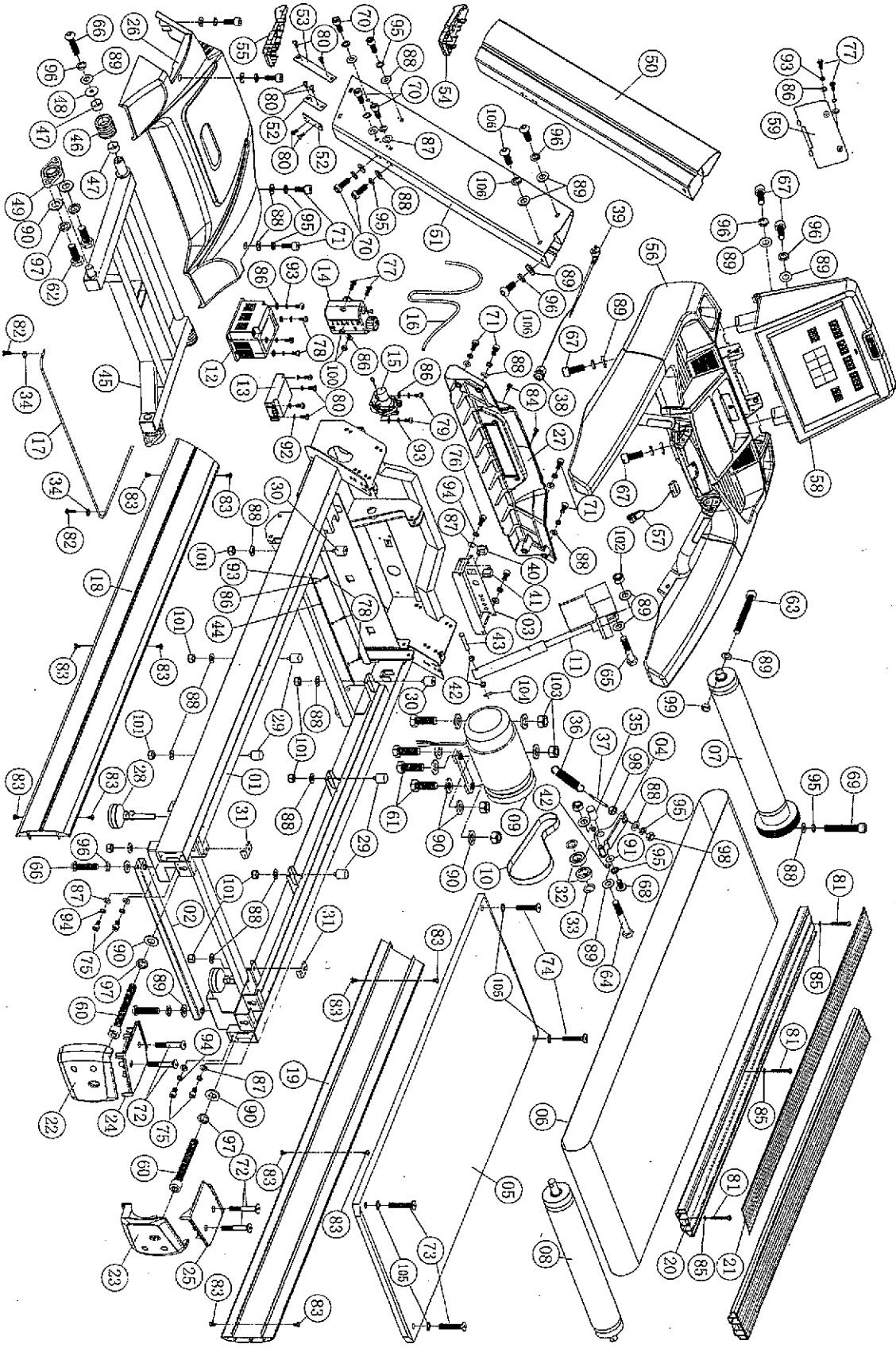

PART LIST

NO.	Part Name	QTY
1	Main Frame	1
2	connected Frame	1
3	Power-box	1
4	Pressure Frame	1
5	Running Board	1
6	Running Belt	1
7	Front Roller	1
8	Rear Roller	1
9	Motor	1
10	Motor Belt	1
11	Incline Motor	1
12	Transducer	1
13	Transformer	1
14	Oil Bottle	1
15	Oil Pump	1
16	Oil Tube	1
17	Oil Tube	1
18	Left trail	1
19	Right trail	1
20	Upper Rail	2
21	Skidproof Rail	2
22	Left Endcap	1
23	Right Endcap	1
24	Left Roller cap	1
25	Right Roller cap	1
26	Motor Cover	1
27	Front-cap	1
28	Adjustable Rear Feet	2
29	Damping Column	4
30	Damping Column	2
31	Rubber Washer	2
32	Rolling Bearing	2
33	Plastic Washer	2
34	Sheet metal	2
35	Gyro Shaft	1
36	Spring	1
37	Bolt	1
38	Intermediate fastening	1
39	Power Cord	1
40	Switch	1
41	Circuit Breaker	1
42	Oilless Bearing	4
43	Axle Pin	1
44	Antistatic brush	1
45	Base Frame	1
46	Wheel	2
47	Oilless Bearing	4
48	Washer	2
49	Spherical bearing	2
50	Support Handle(Left)	1
51	Support Handle(Right)	1
52	Sheet metal	4
53	Sheet metal	2
54	Left tubecap	1
55	Right tubecap	1

PART LIST

NO.	Part Name	QTY
56	Handle	1
57	Safty stop	1
58	Display Console	1
59	Back Cover	1
60	Cheese head bolt	2
61	Hexagon headed bolt	4
62	Hexagon headed bolt	4
63	Cheese head bolt	1
64	Hexagon headed bolt	1
65	Hexagon headed bolt	1
66	Cheese head bolt	4
67	Cheese head bolt	4
68	Cheese head bolt	1
69	Cheese head bolt	1
70	Cheese head bolt	12
71	Cheese head bolt	8
72	Bolt	4
73	Bolt	2
74	Bolt	2
75	Cheese head bolt	4
76	Cheese head bolt	2
77	Philips Screw	4
78	Philips Screw	4
79	Philips Screw	2
80	Philips Screw	19
81	Screw	6
82	Screw	2
83	Screw	12
84	Screw	2
85	Flat Washer	9
86	Flat Washer	10
87	Flat Washer	6
88	Flat Washer	30
89	Flat Washer	19
90	Flat Washer	18
91	Flat Washer	1
92	Grower Washer	7
93	Grower Washer	8
94	Grower Washer	6
95	Grower Washer	23
96	Grower Washer	14
97	Grower Washer	6
98	Hex Nut	2
99	Hex Nut	1
100	Nylon Nut	2
101	Nylon Nut	8
102	Nylon Nut	2
103	Nylon Nut	4
104	Pin	1
105	Taper faced washer	4
106	Cheese head bolt	6
107	Silicon Washer	1
108	Filter	1
109	Reactor	1
110	Safety stop board	1

Correct Disposal of this product



This marking indicates that this product should not be disposed with other household wastes throughout the EU. To prevent possible harm to the environment or human health from uncontrolled waste disposal, recycle it responsibly to promote the sustainable reuse of material resources. To return your used device, please use the return and collection systems or contact the retailer where the product was purchased. They can take this product for environmental safe recycling.